

SPARE PARTS LIST MOTOR FOR KARNASCH  
MAGNETIC HOLE CUTTING MACHINES

ART.: 20 8020 010 TYPE KA38 - 230 VOLT /  
ART.: 20 8020 020 TYPE KA38 - 110 VOLT



ART.: 20 8020 010 TYPE KA38 - 230 VOLT /

ART.: 20 8020 020 TYPE KA38 - 110 VOLT

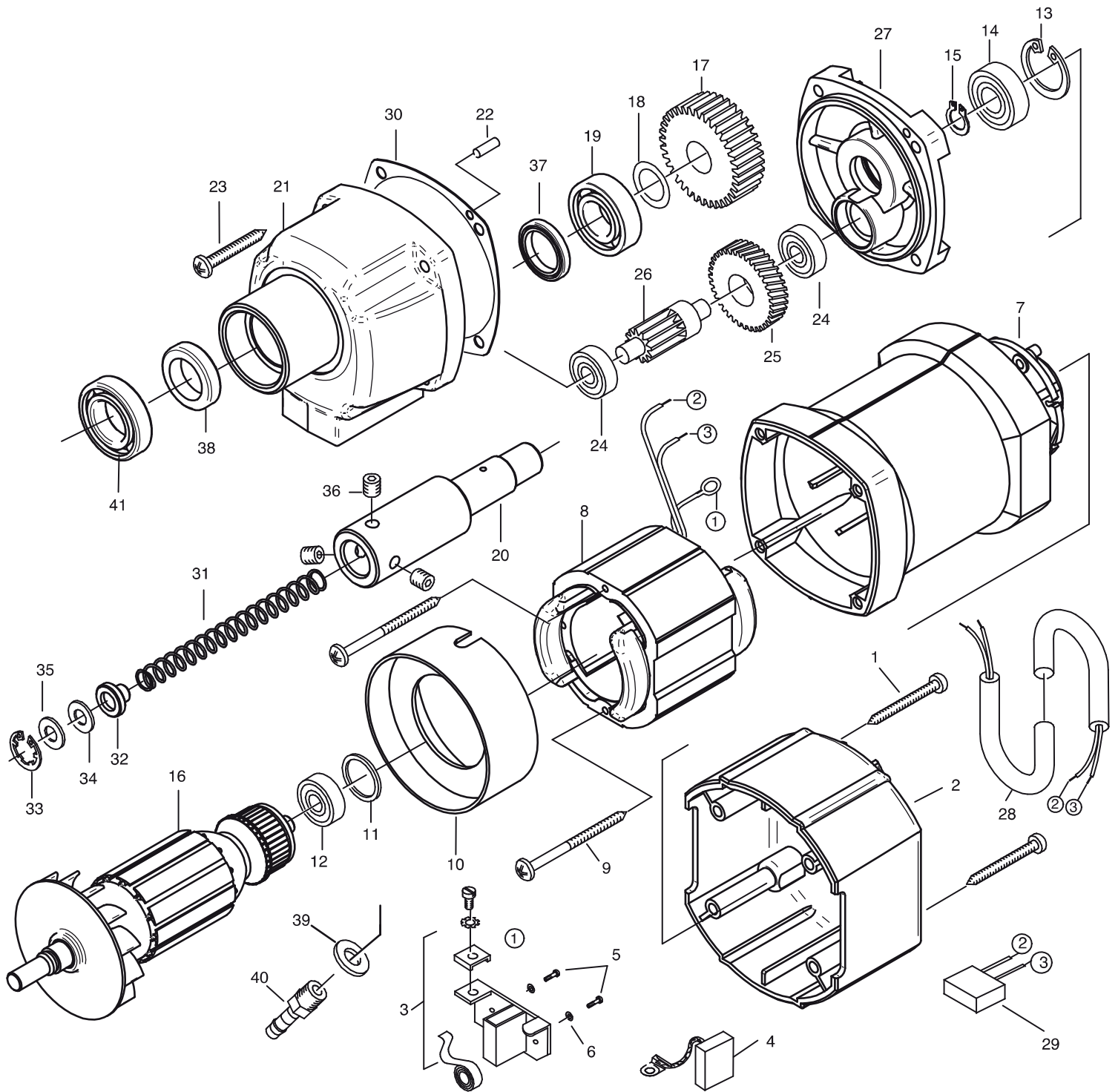

Subject to change

ART.: 20 8020 010 TYPE KA38 - 230 VOLT /  
 ART.: 20 8020 020 TYPE KA38 - 110 VOLT

## MHB 1 - 230 V

no	description	part no	pcs
1	cap screws HC 4,8x50	80201284	4
2	motor top cap with PG9	74222240	1
3	brushholder assem	80201196	2
4	carbon brush 6,3x10x18	80800140	2
5	brushholder mount screwZ M4x12	80201180	4
6	spring washer B4 corrugated	80201385	4
7	motor housing	80900088	1
8	field coil	80800430	1
9	screw C3. 9x60	80201266	2
10	fan ring	80900017	1
11	O-Ring 22x2,5	83000036	1
12	bearing 608 2Z	80410011	1
13	circlip 28/1,2	80201333	1
14	bearing 6001 2Z	80410031	2
15	circlip 10/1	80201305	1
16	armature	77117100	2
17	spindle gear	74010430	1
18	shim washer 17/24x0,2	80200507	2
19	bearing 6003 2RS	80410043	1
20	spindle weldon 19mm	7801L420	1
21	gearbox housing	7411L400	1
22	dowel pin 4x12	80200582	1
23	screw HC4,8x38	80201283	4
24	bearing 608	80410010	2
25	gear	74010470	1
26	gear shaft	74010490	1
27	mid plate	7121E610	1
28	cable Ilex 2x1 <sup>2</sup>	74322340	1
29	suppressor	80500010	1
30	gasket	82000503	1
31	spring 1x9x107	80200801	1
32	piston	7801L425	1
33	circlip JK 19/1	80201350	1
34	o ring	83000027	1
35	washer 13/19x0,5	80200519	1

no	description	part no	pcs
36	secure screw M8x	80200756	3
37	seal D20/28/4	83000028	1
38	seal D20/30/7	83000008	1
39	washer 1/8"	83000106	1
40	hose tail 1 /8"	83000126	1
41	bearing 6904 2RS	80410152	1

## MHB 1 - 110 V

no	description	part no	pcs
8	field coil	80800470	1
16	armature	77118100	1



## RoHS Certificate of Compliance

This document certifies that the part numbers listed in this document and manufactured by **Karnasch Professional Tools** do not to the knowledge of the certifier contain the substances listed in the table below in concentrations exceeding the Maximum Control Value (MCV), and will be compliant as of the date listed.

Substance	Maximum Control Value
Lead	0,1 % by weight (1000 ppm) (1)
Mercury	0,1 % by weight (1000 ppm)
Cadmium	0,01 % by weight (100 ppm) (1)
Hexavalent Chromium	0,1 % by weight (1000 ppm)
Polybrominated Biphenyls (PBB)	0,1 % by weight (1000 ppm)
Polybrominated Diphenyl Ethers (PBDE)	0,1 % by weight (1000 ppm)
(1) The MCV does not apply to applications for which exemptions have been granted to the RoHS Directive.	

Products containing the substances listed in the table above, in concentrations below the MCV, are understood to be in compliance with Directive 2011/65/EU of the European Parliament and of the Council of 8 June 2011 on the restriction of the use of certain hazardous substances in electrical and electronics equipment (RoHS Directive) in accordance with the definitions set forth in the directives.

A list of Karnasch Professional Tools supplied products and the associated RoHS status is given in appendix 1.

Date of Issue: 03. February 16

Place of Issue: KARNASCH PROFESSIONAL TOOLS, Industrial Tools Division, Görsdorf

Signature:

Name: Michael Karnasch

A handwritten signature in blue ink, appearing to read 'Michael Karnasch', is written over a horizontal line.



**Karnasch®**  
PROFESSIONAL TOOLS

Part Number	RoHS Compliant (y/n)	Compliant Since	Planned Start of Production of RoHS compatible components
KA38	y	Start of Production	Available now
KA40/KAS40	y	Start of Production	Available now
KA50/KAS50	y	Start of Production	Available now
KATV55/KATSV55	y	Start of Production	Available now
KA100/KAS100	y	Start of Production	Available now
KATV100/KATSV100	y	Start of Production	Available now
KALP45	y	Start of Production	Available now
KATV140	y	Start of Production	Available now

# Karnasch®

PROFESSIONAL TOOLS

## EC declaration of conformity

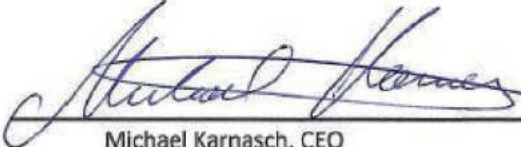
Name/address of the producer:	Karnasch Professional Tools™ Industrial Tools Division Straße des Friedens 10 D – 15848 Tauche / OT Görzdorf
We confirm that the product	
Product:	Magnetic hole cutting machines
Typ:	Hole cutting machine 230/110 volts:  KA40; KA100; KAS40; KA50; KAS50; KATV55; KATV100; KAS100; KATSV55; KASTV100; KALP45; KATV140
complies with the following relevant conditions:	
<ul style="list-style-type: none"> <li>▪ EC-directive 2006/42/EG about machines</li> <li>▪ EC-directive 2004/108/EG about electromagnetic compatibility</li> </ul>	
Following harmonized norms where used in whole or in part:	
<ul style="list-style-type: none"> <li>• DIN EN 61000-6-4:2007 + A1:2011</li> <li>• DIN EN 55014-1:2006 + A1:2009 + A2:2011</li> <li>• DIN EN 55014-2:1997 + Corr. 1997 + A1:2001 + A2:2008</li> <li>• DIN EN 60745-1:2009</li> <li>• DIN EN 60745-2-1:2010</li> </ul>	
Responsible person for the documentation to EC-directive 2006/42/EG is:	
 <hr/> Cindy Burchardt, clerk	
Görzdorf, 11.01.2016	 <hr/> Michael Karnasch, CEO

Karnasch Professional Tools GmbH  
Industrial Tools Division  
Straße des Friedens 10 · 15848 Görzdorf  
Tel. +49(0)33675 7265-0 · Fax +49(0)33675 7101  
e-mail: mail@karnasch.tools  
www.karnasch.tools





## KARNASCH PROFESSIONAL TOOLS®

### CNC TOOLS DIVISION

Siemensstraße 1  
D-68542 Heddeshheim

## KARNASCH PROFESSIONAL TOOLS®

### INDUSTRIAL TOOLS DIVISION

Straße des Friedens 10  
D-15848 Tauche / OT Görzsdorf

### CONTACT

Phone: +49 (0) 6203 4039-0  
Fax: +49 (0) 6203 41590  
E-Mail: [info@karnasch.tools](mailto:info@karnasch.tools)

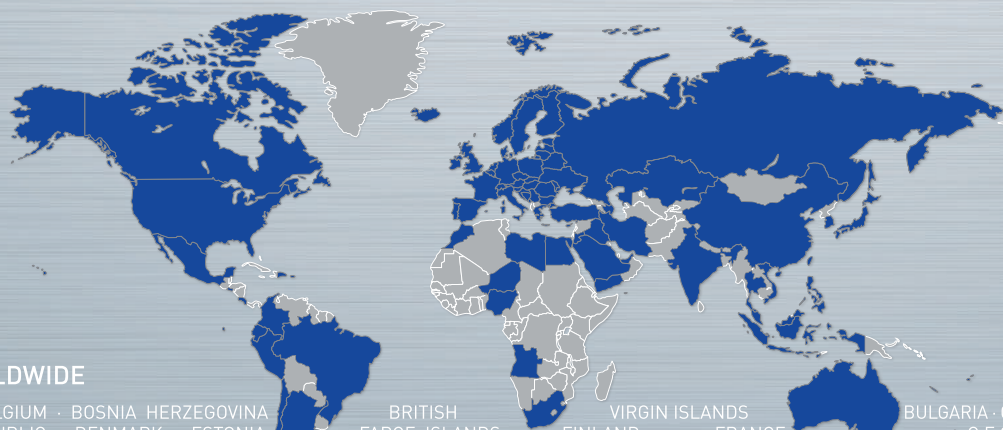

### KARNASCH WORLDWIDE

**EUROPE** AUSTRIA · BELGIUM · BOSNIA HERZEGOVINA · BRITISH VIRGIN ISLANDS · BULGARIA · CROATIA  
CYPRUS · CZECH REPUBLIC · DENMARK · ESTONIA · FAROE ISLANDS · FINLAND · FRANCE · GEORGIA  
GERMANY · GREECE · HUNGARY · ICELAND · IRELAND · ITALY · KOSOVO · LATVIA · LITHUANIA · LUXEMBOURG · MALTA · MOLDOVA  
MONACO · MONTENEGRO · NETHERLANDS · NORWAY · POLAND · PORTUGAL · REPUBLIC OF MOLDOVA · REPUBLIC OF MACEDONIA · ROMANIA  
RUSSIA · SAN MARINO · SLOVAKIA · SLOVENIA · SPAIN · SWEDEN · SWITZERLAND · TURKEY · UKRAINE · UNITED KINGDOM · WHITE RUSSIA/BELARUS  
**AFRICA** ANGOLA · EGYPT · EQUATORIAL GUINEA · LYBIA · MOROCCO · NIGERIA · REPUBLIC OF MAURITIUS · SAUDIA ARABIA · SOUTH AFRICA  
UAE/UNITED ARAB EMIRATES · **ASIA** ARMENIA · AZERBAIJAN · CHINA · DEMOCRATIC PEOPLE'S REPUBLIC OF KOREA · GEORGIA · HONG KONG · INDIA  
INDONESIA · IRAN · ISRAEL · JAPAN · JORDAN · KAZAKHSTAN · KUWAIT · LEBANON · MALAYSIA · PHILIPPINES · QATAR · UAE/UNITED ARAB EMIRATES  
SINGAPORE · SYRIA · TAIWAN · THAILAND · TUNESJEN REPUBLIC · VIETNAM · YEMEN · **SOUTH AMERICA** ARGENTINIA · BRAZIL · CHILE · COLOMBIA  
EQUADOR · PERU · REPUBLIC OF VENEZUELA · **AMERICA** AMERICAN SAMOA · CANADA · USA · **MIDDLE AMERICA** COSTA RICA · EL SALVADOR · MEXICO  
**AUSTRALIA · OCEANIA** CALEDONIA · NEW ZEALAND